



Premier Rheingold 3-Rail Passenger Set

Thank you for purchasing the MTH Premier Line Rheingold Passenger Car Set. The cars' durable ABS body and die-cast trucks are traditionally sized for operation on any O-54 Gauge track.

These cars should operate for years with any AC transformer and are completely compatible with most 3-rail locomotives, rolling stock and accessories.

PLEASE READ BEFORE USE AND SAVE
www.mthtrains.com

Basic Operation & Maintenance

The MTH Premier Rheingold Passenger Cars are easy to operate and feature mechanical operating couplers for realistic uncoupling operation and lighted interiors with overhead illumination. Before operation, the pickup rollers and axles (where they meet the bronze bushings) should be lubricated with light household oil to ensure smooth, consistent electrical contact with a minimum of light flickering inside the car.

Should the lights flicker during operation, the likely cause is insufficient lubrication on the pickup rollers. To lubricate, simply place a drop or two of light household oil on either side of the pickup bracket where the pickup roller is attached.

Set Up

When you open this set, you will see that the diaphragm supports are not installed. To install the diaphragm supports please follow the instructions below.

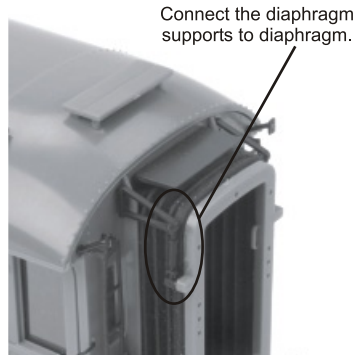
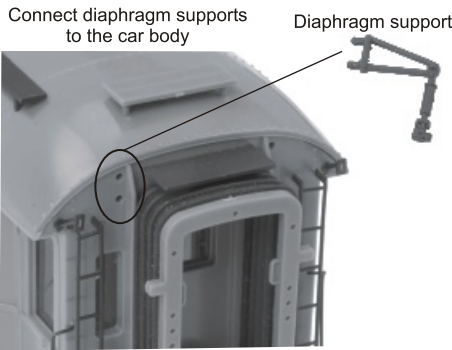

If you would like to install Kadee® Couplers on your cars, do not attach the diaphragm supports. This will allow less tension when the diaphragms touch each other. Kadee® Couplers cannot operate with this set when you have the supports on.

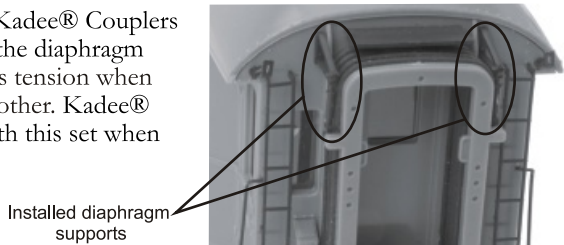

Installing Couplers

The Premier Rheingold Passenger Cars are designed to accept 3 different types of couplers - an operating knuckle coupler, an Ace Coupler and a Kadee® coupler. For your convenience, the operating knuckle coupler and the Ace Couplers have been included with your passenger car set. The Kadee® type can be purchased from a Kadee® coupler retailer. Before you attempt to install the Kadee® Coupler you will need to remove the diaphragm supports if you have attached them. This will allow less tension when the diaphragms touch each other.

The operating knuckle couplers come assembled to the trucks. You must remove these couplers before applying the Ace or the Kadee® couplers. To remove these couplers you must first remove the 4 truck mounting screws and lower the truck from the undercarriage.

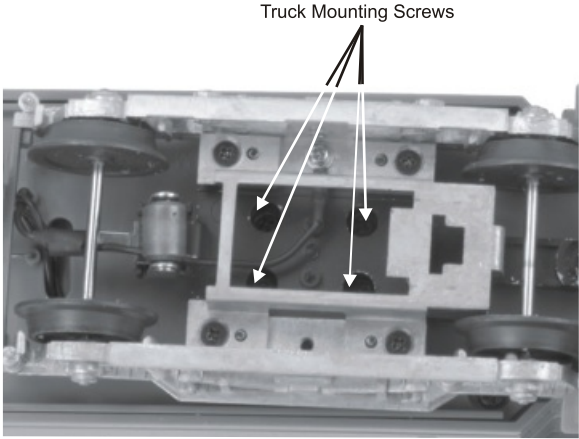

Installing Couplers (Continued)

Then disconnect the wires from the pick-up roller and unscrew the ground wire to free the truck from the car.

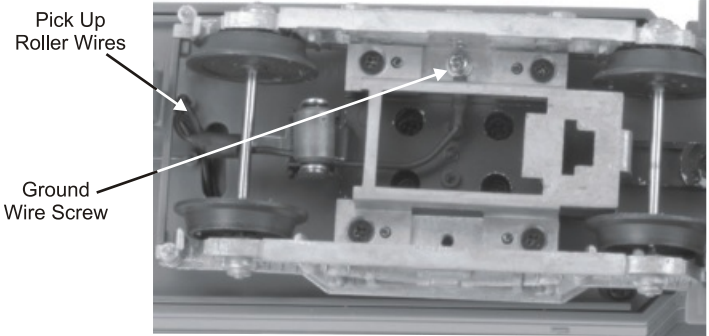

Next you will need to remove the small screw on top of the truck to free the coupler.

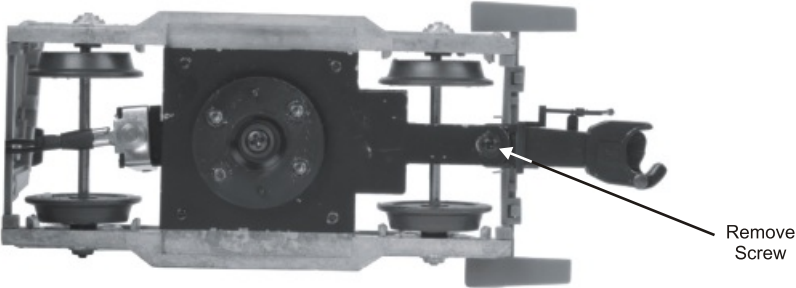

To remove the linkage you will need to remove the 4 truck side screws and remove the truck sides. After the truck sides are removed lower the truck frame and remove the linkage. Then reassemble the truck.

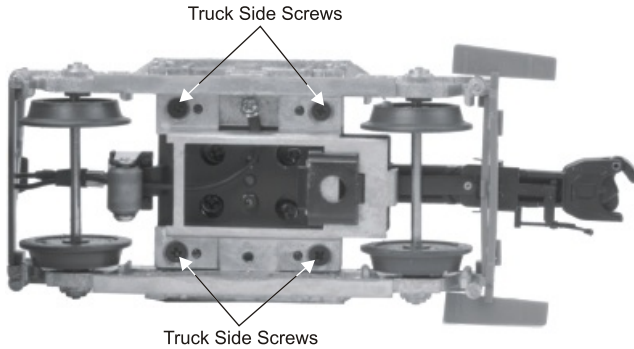

Ace Couplers

To install the Ace couplers place the Ace coupler on top of the truck bolster arm and the small cap on the bottom of the truck bolster arm. Screw the coupler into place with the same small screw that was used on the knuckle coupler. Then reattach the wires and truck to the body in reverse order.

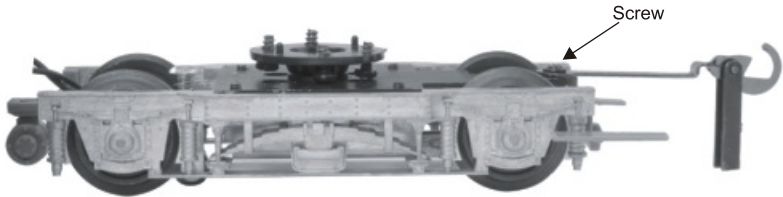

Kadee® Coupler

For your convenience, the Premier Rheingold Passenger Cars are compatible with Kadee® #806 couplers. Kadee® couplers can be purchased from a Kadee® coupler retailer. To install a Kadee® coupler follow the instructions below.

The Premier Rheingold Passenger Cars come set up to operate on O-54 curve track. However if you choose to use a Kadee® Coupler you will need to operate the cars on a larger radius curve track. Remember not to have the diaphragm supports attached prior to attaching the Kadee® Couplers.

To attach the separately purchased Kadee® Coupler, apply the spacer to the undercarriage with two screws. Follow the Kadee Coupler's installation guide for complete details on installing the coupler.

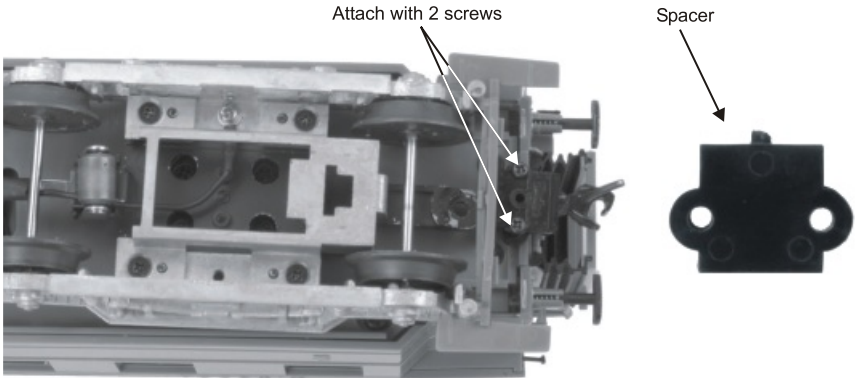

Kadee® is a registered Trademark of Kadee Quality Products Co.

Changing Lights

Occasionally, the lights inside the car may need to be replaced. To replace the lamps follow the disassembly instructions on the following illustrations. Replacement lamps can be obtained directly through MTH Electric Trains (Order online: www.mthtrains.com, e-mail: parts@mth-railking.com, Fax: 410-423-0009, Phone: 410-381-2580, Mail: 7020 Columbia Gateway Drive, Columbia MD 21046-1532,).



To access the lights you will need to remove the roof. To remove the roof pull the sides of the roof out on one end to release the tabs and gently pull up on the roof until it is removed.

Once the roof is removed you will see the two light boards. Remove the 4 screws and lower the boards out. Replace with new light boards and reassemble in reverse order.

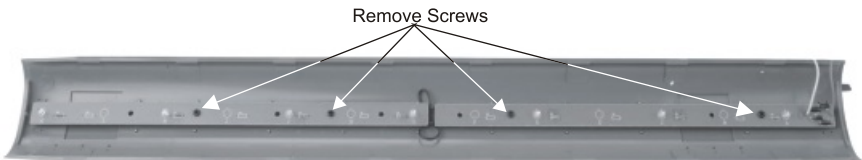

Service & Warranty Information

How to Get Service Under the Terms of the Limited One-Year Warranty

When you suspect an item is defective, please check the operator's manual for standard operation and troubleshooting techniques that may correct the problem. Additional information may be found on the M.T.H. Website. Should you still require service, follow the instructions below to obtain warranty service. First, e-mail, write, call or fax a M.T.H. Authorized Service Center (ASC) in your area to obtain Repair Authorization. You can find the list of ASCs on the M.T.H. Website, www.mthtrains.com. Authorized Service Centers are required to make warranty repairs on items sold only from that store; all other repairs may-- or may not be done at the store's own discretion. If you did not purchase the item directly from the ASC, you will need to select a National Authorized Service Center (NASC). These centers are compensated by M.T.H. to perform warranty service for any customer whose repair qualifies for warranty service. A list of NASC retailers can be located on the M.T.H. Website or by calling 410-381-2580. Should the warranty no longer apply, you may choose either an ASC or NASC retailer to service your M.T.H. Product. A reasonable service fee will be charged.

CAUTION: Make sure the product is packed in its original factory packaging including its foam and plastic wrapping material to prevent damage to the merchandise. There is no need to return the entire set if only one of the components is in need of repair unless otherwise instructed by the Service Center. The shipment must be prepaid and we recommend that it be insured. A cover letter including your name, address, daytime phone number, e-mail address (if available), Return Authorization number (if required by the service center, a copy of your sales receipt and a full description of the problem must be included to facilitate the repairs. Please include the description regardless of whether you discussed the problem with a service technician when contacting the Service Center for your Return Authorization.

Please make sure you have followed the instructions carefully before returning any merchandise for service. Authorized M.T.H. Service Centers are independently owned and operated and are not agents or representatives of M.T.H. Electric Trains. M.T.H. assumes no responsibility, financial or otherwise, for material left in their possession, or work done, by privately owned M.T.H. Authorized Service Centers.

If you need assistance at any time email MTH Service at service@mth-railking.com, or call 410 381-2580.

Limited One-Year Warranty

All M.T.H. products purchased from an M.T.H. Authorized Retailer are covered by this warranty provided the product was manufactured within five years of the date of purchase. This warranty is for the original purchaser and is non-transferable.

See our website www.mthtrains.com to identify an M.T.H. Authorized Retailer near you.

M.T.H. products may be registered online in advance of warranty work at www.mthtrains.com/warranty. The original sales receipt and the conditions below must be met regardless of whether the product is registered on the M.T.H. website in order to obtain warranty service.

M.T.H. products manufactured within five years from the date of purchase are warranted for one year against defects in material or workmanship, excluding wear items such as light bulbs, pick-up rollers, batteries, smoke unit wicks, and traction tires. We will repair, replace, or credit (at our option) the defective part without charge for the parts or labor if the following conditions are met: (1) the item is returned to an M.T.H. Authorized Service Center* (ASC) or M.T.H. National Authorized Service Center (NASC) or M.T.H. Electric Trains Service Department, (2) was manufactured within the previous five years and (3) was purchased within one year of the original date of purchase from an M.T.H. Authorized Retailer. Products manufactured after the five year cutoff from the date of purchase are not covered under any warranty by M.T.H. Electric Trains. The manufacture date of an item can be verified on the item's detail page "shipping date field" on the M.T.H. website (www.mthtrains.com). This warranty does not cover damages caused by improper care, handling, or use. Transportation costs incurred by the customer are not covered under this warranty.

Items sent for repair must be accompanied by a return authorization number, a description of the problem, and a **copy of the original sales receipt from an M.T.H. Authorized Retailer**, which gives the date of purchase. If you are sending this product to an Authorized Service Center, contact that Center for their return authorization.

This warranty gives you specific legal rights, and you may have other rights that vary from state to state. Specific questions regarding the warranty may be forwarded to M.T.H. Directly.

* Authorized Service Centers (ASC) are only obligated to provide warranty service for any consumer who has purchased the specific M.T.H. item from them that requires service work.

Service Department:
M.T.H. Electric Trains
7020 Columbia Gateway Drive
Columbia MD 21046-1532